



Modular ice maker - Scale system Daily production up to 1040 kg

Hotel	██
Restaurant	██
Fast food	██
Bar	██
Disco	██
Fish market	██
Supermarket	██
Medical & SPA	██
Industry	██

► Position n°



► Features & Plus

- Sub-cooled scale ice 99% dry
- 1l (water) - 1kg (ice)
- AISI 304 SS Scotch Brite finish
- Tropical class +43°C
- Specific volume 1 m³ = 430 kg of ice
- Vertical fixed "no leak" evaporator
- Anticorodal alloy evaporator
- Cleanable antiscaling filter
- FDA approved - ABS plastic components
- Easy cleanable internal rounded surfaces
- RoHS Free
- Automatic water charge
- Standard and special voltages
- PS 40bar suction side
- PS 90 bar liquid side
- Electronic expansion valve
- Danfoss Driver
- Mechanical pressure restrictor valve (40bar)
- Remote control board
- Complete electrical panel
- Plug in



AISI 304 SS
Scotch Brite finish

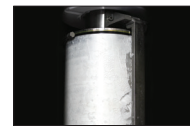

Vertical fixed "no
leak" evaporator



Cleanable
antiscaling filter

► Usable Bins

- Bin 550V DS
- Double Roller Bin 500
- Double Roller Bin 1200

2 Years Warranty

subject to limitations

► Certifications available for this model





Ice Scales

M 1002 Split DEV CO₂



Modular ice maker - Scale system
Daily production up to 1040 kg

► Working conditions

- Location: **Indoor**

	Min	Max
Ambient temperature	+10° C / +50° F	+43° C / 110° F
Water temperature	+3° C / +37° F	+32° C / +90° F
Voltage	-10%	+10%
Water inlet pressure	1bar (14 psi)	6bar (84 psi)

► Connections

- ① Water inlet
- ② Water outlet
- ③ Electrical connection
- ④ Refrigerant feeding pipe
- ⑤ Outlet pipe of gaseous refrigerant

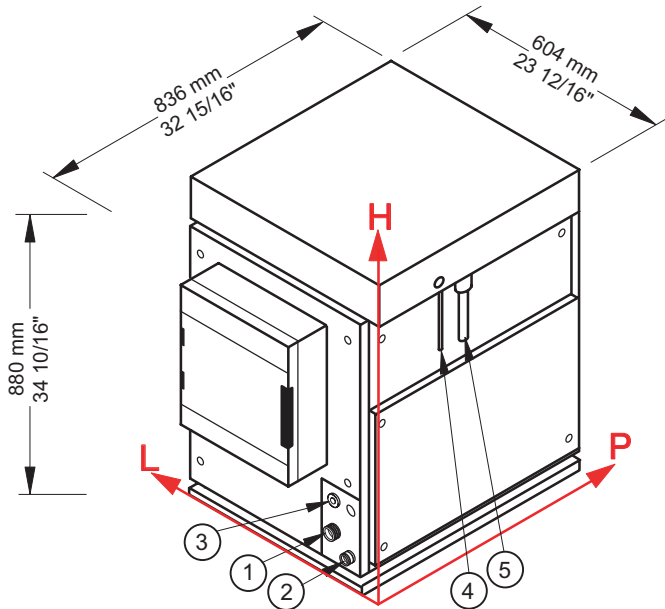

► Technical information

Production in 24h	1040 kg / 2293 lbs
Refrigerant	CO ₂ (R744)
Refrigerant capacity	5000 W (evap. temp. -23° C)
PS liquid side	1305 PSI - 90bar
PS suction side	580 PSI - 40bar
Water consumption	1 l/kg - 12,0 gal/100 lbs
Standard voltage	220-240 V ~ 50 Hz
Average power consumption	180 W

Sizes (L-P-H mm)	604 - 836 - 880
(L-P-H in)	23 12/16 - 32 15/16 - 34 10/16
Sizes with pack (L-P-H mm)	655 - 925 - 1055
(L-P-H in)	25 13/16 - 36 7/16 - 41 9/16
Net weight	140 kg / 309 lbs
Gross weight	160 kg / 353 lbs
Finishing	AISI 304 stainless steel, scotch brite

All the technical information need to be considered at the following conditions:
Refrigerant capacity 5000 W (evap. temp. -23° C)
Water temperature +15° C
Average power consumption at +43° C (standard voltage)

Models and specifications are subject to change without notice

Rev. 04 - Issued September 2019



www.bremaice.it
info@bremaice.it

