

Frozen Frozen granita and cream dispenser with 2 bowls

ITEM # _____

MODEL # _____

NAME # _____

SIS # _____

AIA # _____

560012 (SP2)

Frozen Granita and Frozen Cream Dispenser with 2x5 l insulated bowls (out of production: March 2021)

560013 (SP2ITNK)

Frozen Granita and Frozen Cream Dispenser with 2x5 l bowls (out of production: March 2021)

Short Form Specification

Item No. _____

2x5 lt bowl frozen granita and frozen cream dispenser. Ideal for the production of chilled specialties: creamy desserts, sherbets, mousses and similar products. Works with water or milk/based dried products or with brik mixtures ready to be poured into the bowl. Compact design. The machine automatically stops when the cover is opened. No ice outside the tank with the insulated tank. Rounded shapes with stainless steel finishings and white plastics. All parts that come into contact with the food are in stainless steel or plastic, can be removed for easy cleaning and are dishwasher safe.

Main Features

- Ideal for the production of chilled specialties: creamy desserts, sorbet, mousses and similar products.
- Works with water or milk/based dried products or with brik mixtures ready to be poured into the bowl.
- Perfect solution for bars, restaurants, cafeterias, coffee shops, hotels and all the other HoReCa operators who desire reliable piece of equipment.
- The machine automatically stops when the cover is opened.
- No more ice or condensation outside the tank with the insulated tank.
- Rounded shapes with stainless steel finishings and white plastics.
- Thanks to the two-bowl configurations, it is possible to simultaneously prepare one or more products.
- The insulated tank guarantees higher cooling efficiency and lower effect of the external temperature on product's preparation and maintenance time reducing condensing and draining; it is the best solution in hot climate conditions.

Construction

- All parts that come into contact with the food are in stainless steel or plastic, can be removed for easy cleaning and are dishwasher safe.
- Compact design.

APPROVAL: _____

Front

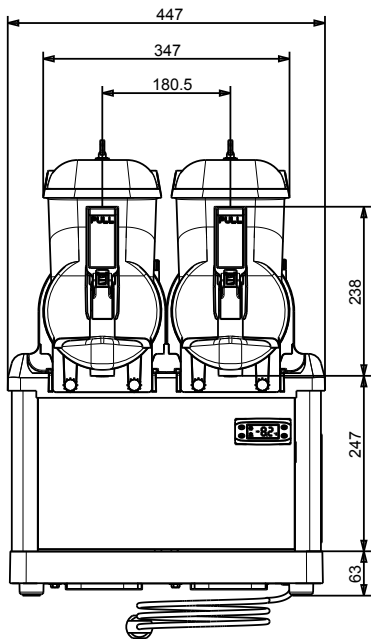

Side

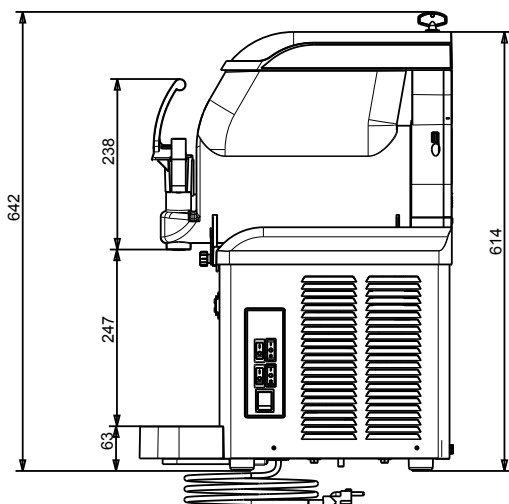

Top

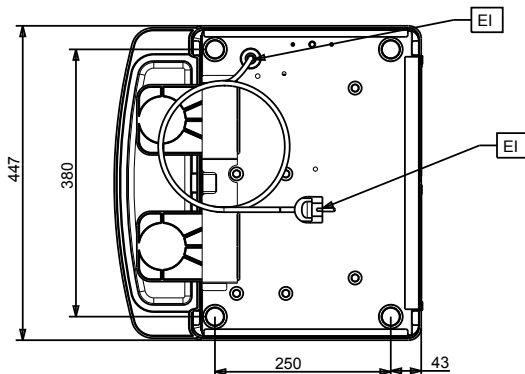

Electric

Supply voltage:

560012 (SP2) 220-240 V/1 ph/50 Hz

560013 (SP2ITNK) 220-240 V/1 ph/50 Hz

Electrical power max.: 0.65 kW

Key Information:

External dimensions, Width: 447 mm

External dimensions, Height: 612 mm

External dimensions, Depth: 438 mm

Net weight: 48 kg

Refrigeration Data

Refrigerant type: R452A