



# HOSHIZAKI

## CM-50KE-HC

### Self-containing Cubelet ice maker. Ice production up to 55kg/24h.

#### MODELS AVAILABLE

☒ CM-50KE-HC

Alternative Flake model: FM-60KE-HC



#### Model code

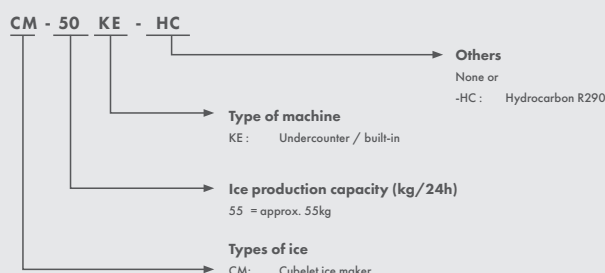

## Storage capacity up to 18kg

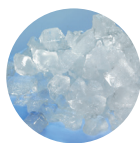

Hoshizaki Cubelet Ice offers a 90% ice to water ratio and ensuring maximum cooling effect.

In cocktails, the dry and hard ice cubelets are the ideal cooling agent, as they deliver just the right amount of dilution, especially for strong spirited drinks, for example, Mojitos and Tiki Cocktails.

Powered by R290 Natural Refrigerant, energy efficient and sustainable, with a GWP = 3.



PRODUCT SERIES: CM  
ITEM NUMBER: F161-C103

This Hoshizaki CM-50KE-HC is a self contained cubelet ice maker producing up to 55kg of high-quality cubelet ice per 24 hours.

Hoshizaki CM ice makers produce cubelet ice. In cocktails, the dry and hard ice cubelets are the ideal cooling agent, as they deliver just the right amount of dilution, especially for strong spirited drinks, for example, Mojitos and Tiki Cocktails. The ice maker's extruding head performs a high compression to yield harder and drier cubelets, combining the characteristics of nugget and cube ice.

#### Material:

The exterior is made of stainless steel. The closed water circuit provides maximum protection against any type of contamination during the entire ice production process. All Hoshizaki machines are easy to use, clean and maintain.

#### Unique Technology:

The CM series has a worktime-based replacement system, which can be monitored with an intuitive control display for preventive maintenance. Hoshizaki was the first to introduce an automated water circuit rinse cycle, to avoid harmful mineral residues from damaging the ice making system and maintaining top sanitary conditions.

#### Smart Design:

The self contained Cubelet ice maker uses carbon graphite bushings instead of conventional ball bearings which allows the machine to work entirely without grease. Here, the absence of moving parts prevents wear and tear, while the water-lubricated bearings protect the system from unpleasant calcification and bacterial contamination.

#### Perfect Fit:

With outside dimensions of 498 x 570 x 697mm (W x D x H), the CM-50KE-HC is compact and makes a perfect fit for small spaces.



COMMERCIAL WARRANTY AGAINST MANUFACTURING DEFECTS

PARTS **2** YEARS

#### EXTERIOR FINISH

Stainless Steel,  
Galvanized Steel (Rear)

Refrigerant: R290 / 50g

#### OPERATING CONDITIONS LIMITATIONS

- Ambient temperature range: 5°C / 40°C
- Water temperature range: 5°C / 35°C
- Water supply pressure: 0.5 bar min. / 8 bar max.
- Voltage range: rated voltage ±6%

MODEL	Cooling	Max. production in 24h Air 10°C Water 10°C (kg)	Ice storage bin capacity (kg)	Electric connection	Electrical circuit breaker protection (A)	Electrical consumption power factor 80% (W)	Water consumption liters m <sup>3</sup> /24h @10°C/10°C
CM-50KE-HC	Air	55	18	1/220-240V/50Hz	6	270	0.065

#### TECHNICAL CERTIFICATIONS



For more information visit our website at [www.hoshizaki-europe.com](http://www.hoshizaki-europe.com)  
Hoshizaki Europe B.V. retains the right to change products and their specifications without prior notice.

**Hoshizaki Europe B.V.**  
Burgemeester Stramanweg 101,  
1101 AA Amsterdam  
The Netherlands

T: +31 (0)20 691 8499  
sales@hoshizaki.ae  
[www.hoshizaki-europe.com](http://www.hoshizaki-europe.com)



# HOSHIZAKI

LEADING NATURALLY

## CM-50KE-HC

Self-containing Cubelet ice maker.  
Ice production up to 55kg/24h.

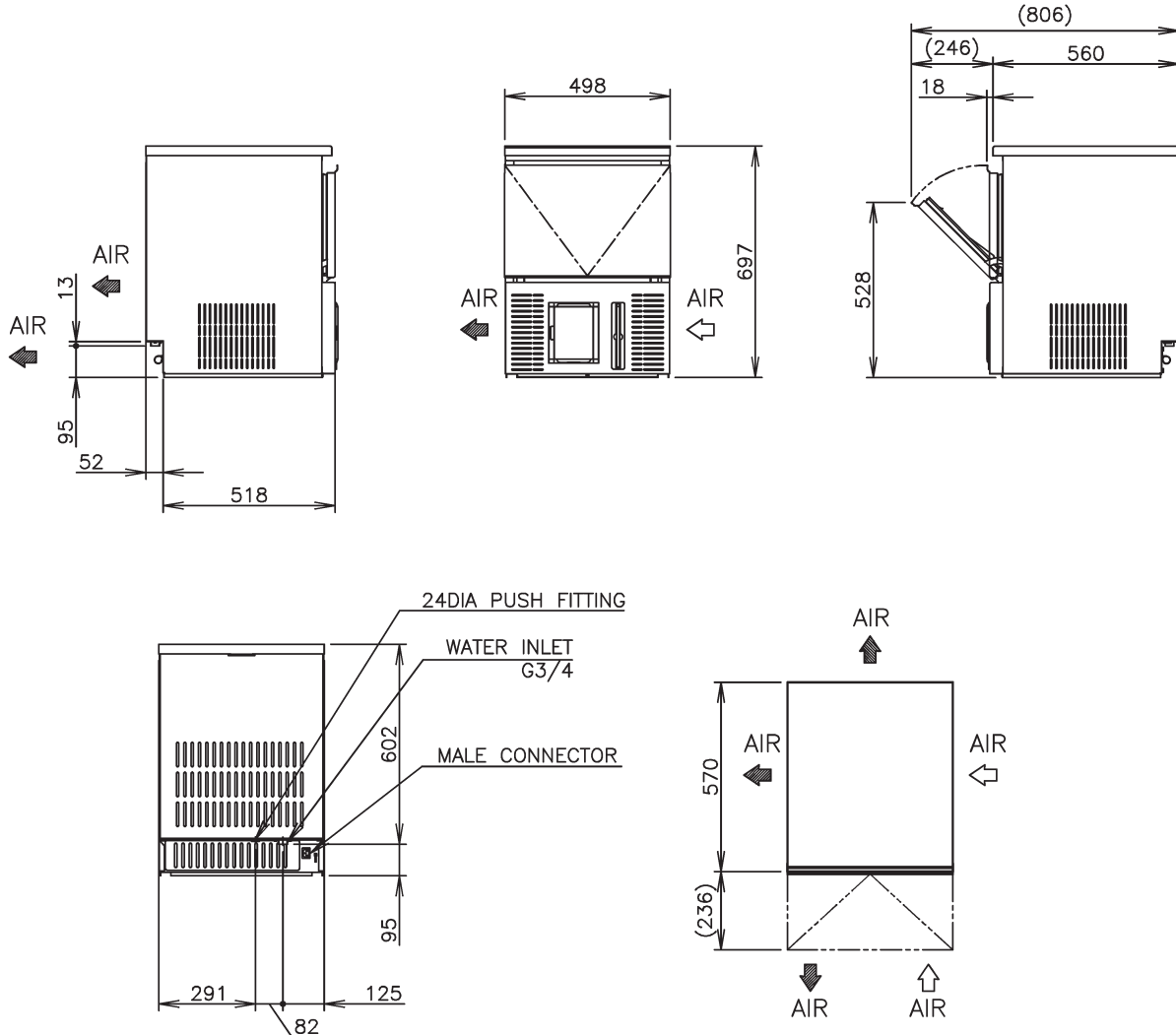

### SHIPPING SPECIFICATIONS

MODEL	Net equipment dimensions		Crated dimensions		
	W x D x H (mm)	Net weight (kg)	W x D x H (mm)	Gross weight (kg)	Volume (m <sup>3</sup> )
CM-50KE-HC	498 x 570 x 697	49	595 x 680 x 873	58	0.35

- ACCESSORIES
- Scoop
  - Installation Kit
  - Legs (not included)



Hoshizaki Belgium: info@hoshizaki.be  
 Hoshizaki Denmark: info@hoshizaki.dk  
 Hoshizaki Deutschland: info@hoshizaki.de  
 Hoshizaki France: info@hoshizaki.fr  
 Hoshizaki Iberia: info@hoshizaki.es  
 Hoshizaki Italia: info@hoshizaki.it  
 Hoshizaki Middle East: sales@hoshizaki.ae

Hoshizaki Netherlands: info@hoshizaki.nl  
 Hoshizaki Norge: info@hoshizaki.no  
 Hoshizaki United Kingdom: uksales@hoshizaki.uk  
 Hoshizaki Sverige: orderSE@hoshizaki.dk  
 Export Countries: sales@hoshizaki.nl  
 Other countries: sales@hoshizaki.nl

[www.hoshizaki-europe.com](http://www.hoshizaki-europe.com)